

## FEATURES

MODEL		DF100B	DF90A/80A/70A	DF90ATH/80ATH/70ATH
BODY COLOR	PEARL NEBULAR BLACK	●	●	●
	COOL WHITE	●	●*	
2-STAGE GEAR REDUCTION SYSTEM		●	●	●
HYDRODYNAMIC GEAR CASE		●	●	●
OFFSET DRIVESHAFT		●	●	●
DIRECT IGNITION		●	●	●
SELF-ADJUSTING TIMING CHAIN		●	●	●
SUZUKI LEAN BURN CONTROL SYSTEM		●	●	●
SUZUKI EASY START SYSTEM		●	●	●
OVER-REV. LIMITER		●	●	●
LOW OIL PRESSURE CAUTION		●	●	●
FRESH WATER FLUSHING SYSTEM		●	●	●
SUZUKI TROLL MODE SYSTEM		○	○	●
TILT LIMIT SYSTEM		●	●	●
WATER DETECTING SYSTEM		●		

\* DF90A/70A only

●=Standard Equip. ○=Optional Equip.

## DF100B/90A/80A/70A SPECIFICATIONS

MODELS	DF100B	DF90A	DF80A	DF70A
ENGINE TYPE	4-stroke DOHC 16 valves			
FUEL DELIVERY SYSTEM	Multi Point Sequential Electronic Fuel Injection			
RECOMMEND TRANOM HEIGHT mm (in.)	L: 508 (20), X: 635 (25)			
STARTING SYSTEM	Electric			
WEIGHT kg (lbs.)*	L: 157, X: 161	L: 156, X: 160		
NO. OF CYLINDERS	Inline 4			
PISTON DISPLACEMENT cm <sup>3</sup> (cu.in.)	1,502 (91.7)			
BORE × STROKE m/m (in.)	75 × 85 (3.0 × 3.3)			
MAXIMUM OUTPUT kW (PS)/rpm	73.6 (100)/6000	66.2 (90)/5800	58.8 (80)/5500	51.5 (70)/5500
FULL THROTTLE OPERATING RANGE rpm	5700-6300	5300-6300	5000-6000	
STEERING	Remote			
OIL PAN CAPACITY l (US/lpm.qt.)	4.0 (4.2/3.5)			
IGNITION SYSTEM	Fully-transistorized			
ALTERNATOR	12V 27A			
ENGINE MOUNTING	Shear Mount			
TRIM METHOD	Power Trim and Tilt			
GEAR RATIO	2.59 : 1			
GEAR SHIFT	F-N-R			
EXHAUST	Through Prop Hub Exhaust			
DRIVE PROTECTION	Rubber Hub			
PROPELLER SIZE (in.)** 3-BLADE ALUMINUM	13"-23"			

\* With battery cable, without propeller & engine oil.

\*\* Boats and motors come in a large variety of combinations. See your authorized dealer for correct prop. selection to meet recommended RPM range at W.O.T.

Please read your owner's manual carefully. Remember, boating and alcohol or other drugs don't mix. Always use a personal flotation devise. Please operate your outboard safely and responsibly. Suzuki encourages you to operate your boat safely and with respect for the marine environment.

Specifications, appearances, equipment, colors, materials and other items of "SUZUKI" products shown on this catalogue are subject to change by manufacturers at any time without notice and they may vary depending on local conditions or requirements. Some models are not available in some territories. Each model might be discontinued without notice. Please inquire at your local dealer for details of any such changes. Actual body color might differ from the colors in this brochure.

## DIMENSIONS

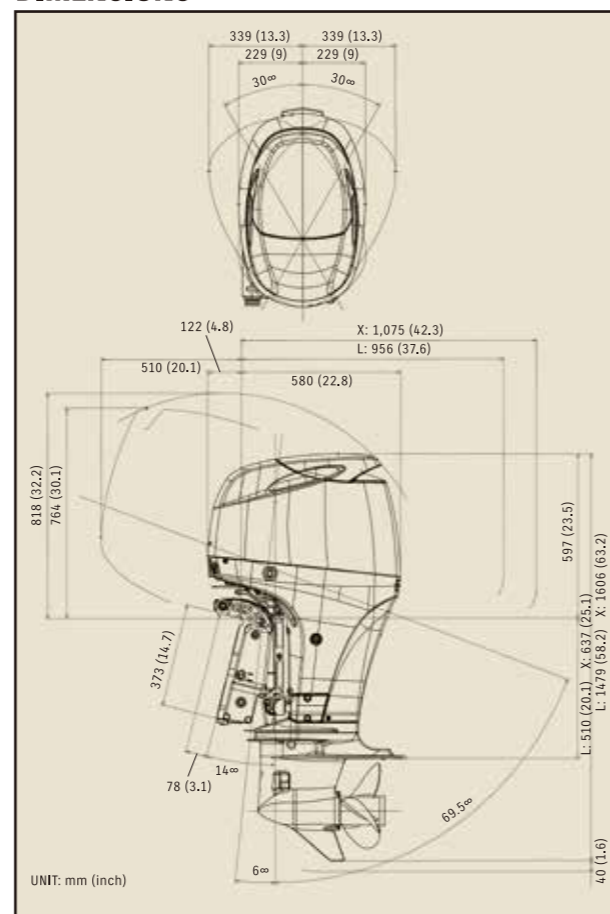

Way of Life!



## PRODUCT INFORMATION DF100B/90A/80A/70A



THE  
**ULTIMATE**  
OUTBOARD MOTOR

# A NEW STANDARD IN FOUR-STROKES FROM SUZUKI

## DF100B

# 1 OVERWHELMINGLY LIGHT, LIGHTEST IN CLASS

L:157kg, the lightest weight in 100ps class. (SUZUKI internal reserch)

# 3 THE LARGEST REDUCTION GEAR RATIO

2.59:1, the greatest reduction gear ratio in 100ps class. (SUZUKI internal reserch)

# 5 STYLISH FORM

- Three-dimensional S chrome emblem
- One and only white model in 100ps class



157kg

# 2 COMPACT

- 100ps from a DF90A engine body
- Offset drive shaft for compact body

# 4 FULL EQUIPMENT



OFFSET DRIVESHAFT



2.59 GEAR RATIO



LEAN BURN



SELF-ADJUSTING TIMING CHAIN



WATER DETECTING SYSTEM



TILT LIMIT SYSTEM



SUZUKI TROLL MODE SYSTEM (OPTIONAL)

# PRODUCT INFORMATION

## DF100B/90A/80A/70A

### POWERFUL



#### OFFSET DRIVESHAFT

**EXPLANATION :** The engine powerhead is positioned closer to the front, moving the outboard's center of gravity forward.

- ADVANTAGE :**
- Less vibration
  - More compact engine
  - Stable steering performance

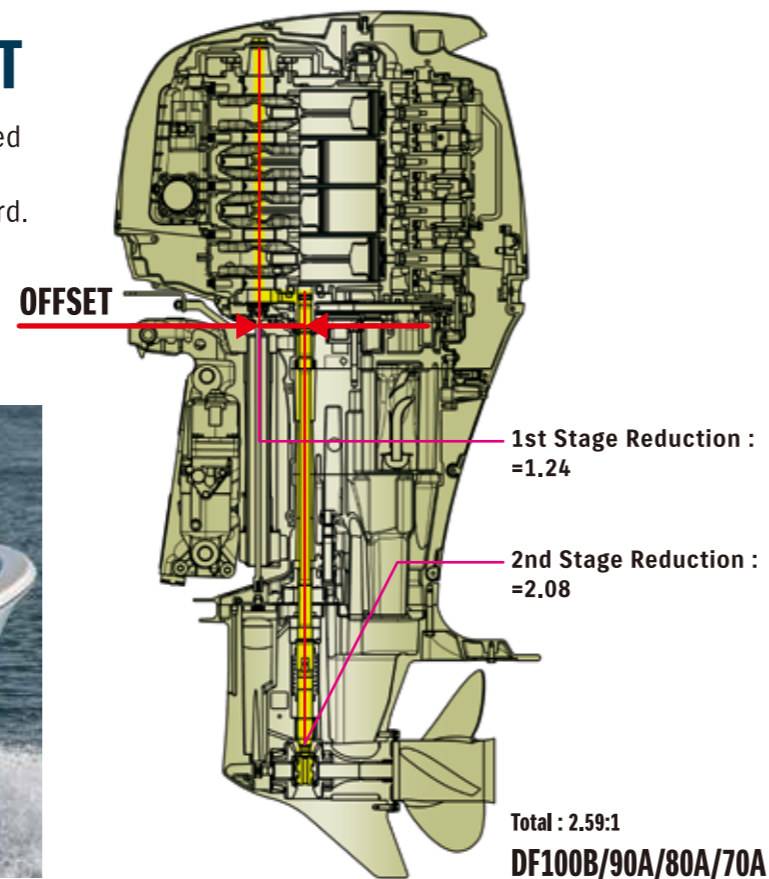

#### 2-STAGE GEAR REDUCTION

**EXPLANATION :** This system which incorporates the Offset Driveshaft features a first stage reduction between the crankshaft and drive shaft and a second stage reduction inside the gear case. This design makes a larger gear ratio possible, allowing it to turn a large diameter propeller for high propulsive efficiency while providing higher torque.

- ADVANTAGE :**
- High propulsive efficiency with large diameter propeller.
  - Powerful navigation, maintaining propeller rotation even with a larger load.
  - Tremendous power to turn large diameter propellers, offering quick acceleration.

These reduction gear ratios are the largest in each class.

MODEL	DF100B/90A/80A/70A
GEAR RATIO	2.59:1

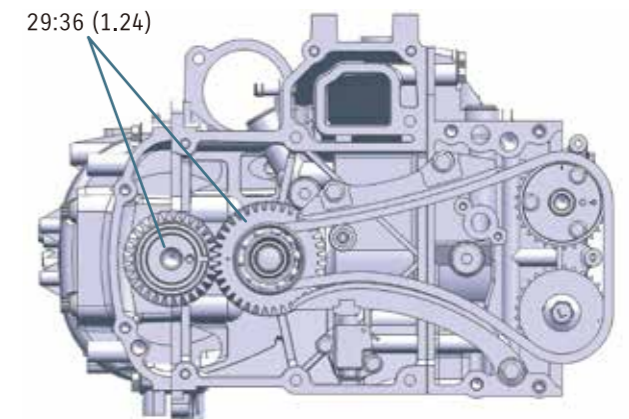

### FUEL EFFICIENT



#### LEAN BURN

LEAN BURN

**EXPLANATION :** The Lean Burn Control System supplies the right fuel and air mixture depending on the navigation conditions.

- ADVANTAGE :**
- Significant improvement in fuel economy in all speed ranges especially at cruising speed.
  - Fuel costs can be saved thanks to improved fuel economy.

### USER FRIENDLY

#### Suzuki Easy Start System

The Suzuki easy start system no longer require to hold the key until the engine start. Now simply turn the key and release and the starter will stay engaged until the engine starts.

The system also features more precise cylinder detection, fuel injection, and ignition control to deliver smoother and improved starts, more efficient combustion, and greater fuel economy making the outboard more environmentally friendly.

# PRODUCT INFORMATION

## DF100B/90A/80A/70A

## HIGH PERFORMANCE FEATURES

### STREAMLINED GEAR CASE AND HIGHLY EFFICIENT PROPELLER

The lower gear case on all four outboard motors utilizes a hydrodynamic design. As the lower unit moves through the water its sleek form reduces drag by up to 36% compared to conventional designs, contributing to faster acceleration and increased speed.

Thanks to the powerful torque delivered with Suzuki's two-stage gear reduction, these outboards can turn a large diameter propeller. Suzuki engineered a new highly efficient propeller that takes advantage of this torque to provide faster acceleration and higher top speed.

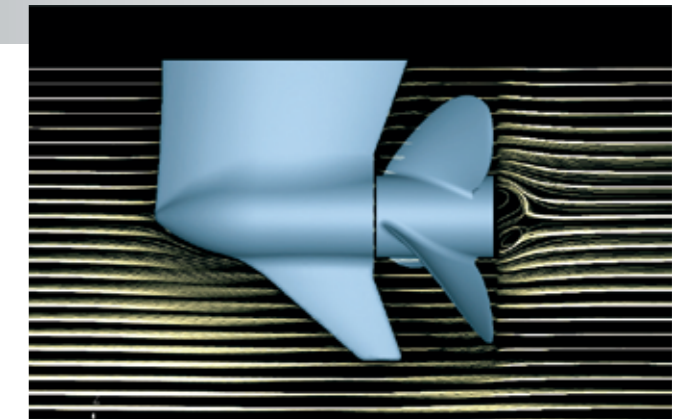

## RELIABLE



### SELF-ADJUSTING TIMING CHAIN

**EXPLANATION :** The timing chain runs in an oil-bath so it never needs lubricating, and is equipped with an automatic hydraulic tensioner so it remains properly adjusted at all times.

**ADVANTAGE :** ■ Higher durability compared to belt types.  
■ Maintenance-free.



### WATER DETECTING SYSTEM

THIS EQUIPMENT IS ONLY FOR DF100B

**EXPLANATION :** It helps protect the engine from water in the fuel using a water detecting fuel filter to alert the operator with both visual and audio warnings when water is present in the fuel.

**ADVANTAGE :** ■ Can avoid water in fuel, which can lead to issues like poor combustion, lower power output and corrosion

### SUZUKI'S ANTI CORROSION FINISH

Bonding the finish to the outboard's alloy surface our specially formulated anti-corrosion finish has long been used as an effective treatment against corrosion and is found on all of our outboards.

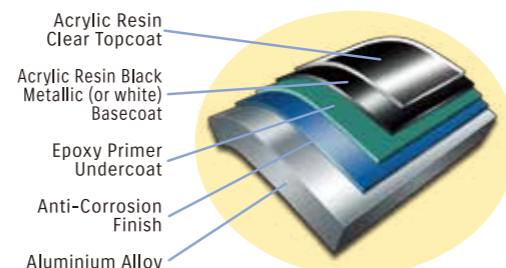

## INNOVATIVE



### TILT LIMIT SYSTEM

**EXPLANATION :** A tilt limit system that prevents the outboard from tilting beyond a certain angle.

**ADVANTAGE :** ■ Prevents damage to the boat or outboard due to excessive outboard tilting.

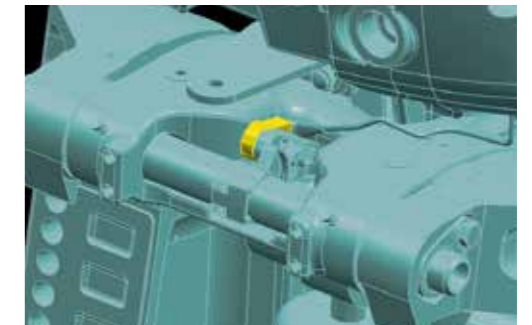

### SUZUKI TROLL MODE SYSTEM (OPTIONAL EQUIPMENT)

**EXPLANATION :** A system that can move the boat at a constant speed.

**ADVANTAGE :** ■ Boat can be moved at a constant speed without operating the throttle.



### DUAL ENGINE FLUSH PORTS

Over time, salt, sand, and dirt build up can restrict flow in the cooling system causing damage. To help prevent such buildup, DF100B/90A/80A/70A are equipped with two freshwater flush ports that make flushing the cooling system much easier. With one port located on the port side of the down housing and a second on the front panel, you'll always have easy access to the flushing system whether the boat is in or out of the water.

