



Way of Life!

# PRODUCT INFORMATION

## A word from Suzuki engineers



### Masaya Nishio (Electronics Design)

To reduce vibration on the new DF50/40, we utilized a trim control similar to the one used on the DF60, which delivers performance comparable to the devices used on our high-end outboards. In order to install the trim sensor in the narrow space inside of the clamp bracket, we redesigned the sensor reducing the number of parts and making it more compact. We also looked closely at its mounting position and the shape of the lever design to increase smooth operation of the gauge display while trimming.

increase smooth operation of the gauge display while trimming.

### Satoru Fukuchi (Body Design)

The tiller handle on the new DF50TH/40QH features a new mid-section steering adjuster. Moving the adjuster from its position on the rear of the outboard to a more forward position provides the user with improved operability. This also eliminates the need to lean out of the boat when making adjustments providing greater operating safety. We will continue our efforts to bring more comfortable boating to our customers.



### Ryuuji Hamada (Experiment and Evaluation)

I was in charge of bringing lean burn to the new DF50/40. The engine displacement of new DF50/40 is larger than its predecessor. While a larger displacement would usually be disadvantageous in fuel cost, the lean burn system provides the new DF50/40 with fuel economy that is better than their predecessors.



### Hiromichi Takewaki (Engine Design)

Fuel economy was an important focal point in developing the new DF50/40. In order to gain the improvement we sought, we focused on optimizing volumetric efficiency and combustion efficiency. We were able to maximize volumetric efficiency by using fluid analysis to optimize flow through the intake passageway. Combustion efficiency was improved using our most advanced fuel injection system and decreasing atomization by 50% compared to the original DF50/40. Just like the rest of the DF series outboards, these outboards are designed to be compact and lightweight. By optimizing the weight of each part, we managed to reduce the outboard's overall weight by 6kg (DF50T/40T Transom L) while increasing displacement compared to the original DF50/40. I am completely satisfied with the solutions we devised to the challenges we encountered in designing the new engine.

the original DF50/40. Just like the rest of the DF series outboards, these outboards are designed to be compact and lightweight. By optimizing the weight of each part, we managed to reduce the outboard's overall weight by 6kg (DF50T/40T Transom L) while increasing displacement compared to the original DF50/40. I am completely satisfied with the solutions we devised to the challenges we encountered in designing the new engine.

### Toshio Watanabe (Development)

We used computer analysis a great deal to analyze strength in the design of the new DF50/40. We focused a lot on the components used for attaching the outboard to the hull, which are similar to those used in automobile suspensions, as well as some other major parts. Another area of focus was on the state in the engine cover where heat is easily trapped. The air used for engine combustion travels through this space so we looked for and found solutions to lower the air temperature here to supply more efficient engine operation.



## DF50/40 SPECIFICATIONS

MODELS	DF50TH	DF50T/40T	DF40QH
ENGINE TYPE	4-stroke DOHC 12-valve		
FUEL DELIVERY SYSTEM	Multi Point Sequential Electronic Fuel Injection		
RECOMMENDED TRANSOM HEIGHT mm (in.)	L: 508(20)	S: 381 (15), L: 508 (20)	L: 508 (20)
STARTING SYSTEM	Electric		
WEIGHT kg (lbs.) *	L: 108 (238)	S: 102 (225), L: 104 (229)	L: 106 (234)
NO. OF CYLINDERS	Inline 3		
PISTON DISPLACEMENT cm <sup>3</sup> (cu.in.)	941 (57.4)		
BORE x STROKE m/m (in.)	72.5 x 76.0 (2.85 x 2.99)		
MAXIMUM OUTPUT kW (PS)/rpm	DF50: 36.8 (50)/5,800, DF40: 29.4 (40)/5,500		
FULL THROTTLE OPERATING RANGE rpm	DF50: 5,300 - 6,300, DF40: 5,000 - 6,000		
STEERING	Tiller	Remote	Tiller
OIL PAN CAPACITY ℓ (US/lpm.qt.)	2.7 (2.9/2.4)		
IGNITION SYSTEM	Fully-transistorized		
ALTERNATOR	12V 19A		
ENGINE MOUNTING	Shear Mount		
TRIM METHOD	Power Trim and Tilt	Manual Trim and Gas Assisted Tilt	
GEAR RATIO	2.27 : 1		
GEAR SHIFT	F-N-R		
EXHAUST	Through Prop Hub Exhaust		
DRIVE PROTECTION	Rubber Hub		
PROPELLER SIZE (in.)	11-1/2 x 9                      11-3/8 x 14		
Diameter x Pitch	11-1/2 x 10                      11-1/4 x 15		
	11-1/2 x 11                      11-1/8 x 16		
	11-5/8 x 12                      11            x 17		
	11-1/2 x 13		

\* With battery cable, without propeller & engine oil.

Please read your owner's manual carefully. Remember, boating and alcohol or other drugs don't mix. Always use a personal flotation device. Please operate your outboard safely and responsibly. Suzuki encourages you to operate your boat safely and with respect for the marine environment.

Specifications, appearances, equipment, colors, materials and other items of "SUZUKI" products shown on this catalogue are subject to change by manufacturers at any time without notice and they may vary depending on local conditions or requirements. Some models are not available in some territories. Each model might be discontinued without notice. Please inquire at your local dealer for details of any such changes. Actual body color might differ from the colors in this brochure.

## DIMENSIONS

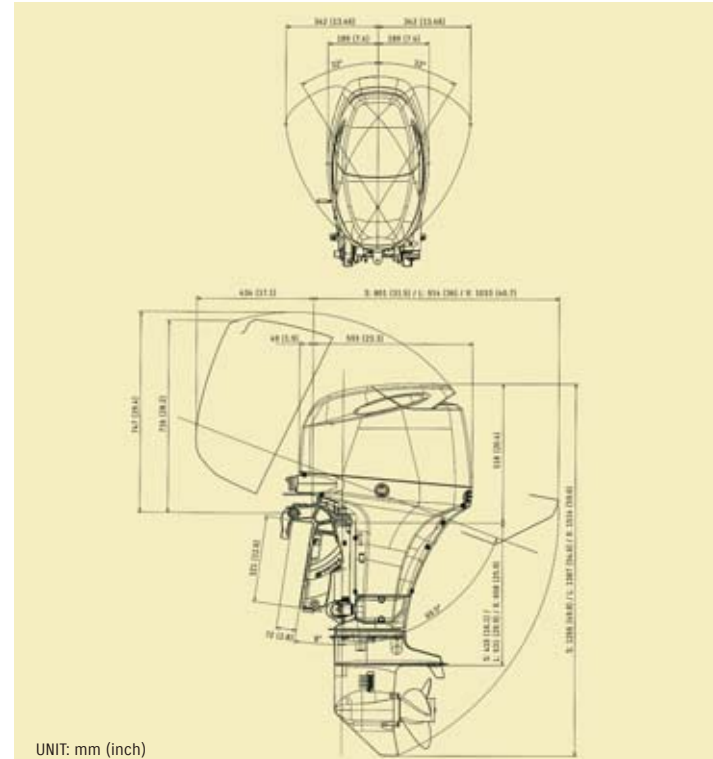

UNIT: mm (inch)



# DF50/40 Lean Burn



300 TAKATSUKA-CHO, MINAMI-KU, HAMAMATSU CITY, JAPAN 432-8611



# Delivering Superior Fuel Efficiency and High Performance— The New Generation DF50 and DF40

Today's outboards must be highly economical and deliver environmentally responsible operation. Using our unique vision and innovative technologies, we at Suzuki are constantly seeking new ways to provide our customers all over the world with outboards that meet these requirements and deliver satisfaction and excitement.

With the new DF50 and DF40, the latest additions to Suzuki's fleet of fuel-efficient new generation four-stroke outboards, Suzuki engineers have combined a high performance DOHC (dual overhead cam) engine with Suzuki's Lean Burn Control System to create an outboard that delivers superior power and performance along with top-level fuel economy.

Based on Suzuki's proven in-line three-cylinder design with four valves per cylinder, this all-new engine utilizes a highly efficient air intake system that delivers maximum effectiveness in the high rpm range for high performance power. This is the only engine in the 36.8kW (50PS)/29.4kW (40PS) outboard class to offer DOHC performance, and also the only engine in its class to incorporate a maintenance-free, oil-bathed timing chain, which provides the outboard with increased durability and maintenance free operation. Additional features include electronic fuel injection, Suzuki's easy start system, and a large capacity 19A alternator.

With larger displacements for increased power and performance, Suzuki's Lean Burn Control System for improved fuel economy, and designs that are more compact and lighter in weight than their predecessors, the new DF50 and DF40 are an excellent choice for today's boaters.

## Features

- High performance DOHC 12-valve engine
- Suzuki's innovative Lean Burn Control System delivers remarkable fuel efficient operation
- Electronic Fuel Injection delivers optimum performance
- Maintenance-free timing chain
- Large capacity 19A alternator

## Mechanically Efficient DOHC 12-Valve Engine

Suzuki engineers based the new DF50 and DF40 engine on Suzuki's proven in-line three-cylinder 12-valve engine. This high performance engine has a displacement of 941cm<sup>3</sup> and features a DOHC powerhead—the only DOHC engine used in the 36.8kW (50PS)/29.4kW (40PS) outboard class—with four valves per cylinder, and an air intake system optimized for maximum efficiency in the high rpm range. When designing this engine, Suzuki engineers also focused on improving mechanical efficiency. Each component was analyzed and redesigned to reduce mechanical loss in order to improve efficiency. As an example, a new oil pump design makes internal oil flow more efficient, keeping moving parts better lubricated while using less energy. The combined reduction in mechanical loss throughout the engine contributes to better fuel economy.



### Cleaner, Efficient Operation

Suzuki's advanced four-stroke technologies deliver clean and efficient outboard operation that conforms to EURO 1 Emissions Standards (EU Directive 2003/44/EC)—the EU emissions standards (exhaust gases and noise levels) set by the European Parliament and the Council, and have received three-star ratings from the California Air Resources Board (CARB).



## Suzuki's Lean Burn Control System

Suzuki's Lean Burn Control System is an intelligent system that monitors engine performance and operating conditions to predict fuel needs and deliver a leaner fuel mixture to the engine. First introduced on the DF90/80/70, and later on the DF60, this system provides remarkable improvements in fuel economy from low speed operation up into the cruising range, which is where the engine is used a majority of the time. In-house testing shows that at medium speeds, the new

DF50 achieves a 23% improvement in fuel consumption than its predecessor.

## Suzuki Easy Start System

Starts are quick and easy with Suzuki's Easy Start System. No need to hold the key, just turn it once and the starter system stays engaged until the engine starts. The system delivers smoother and improved starts to get you up and running quicker.

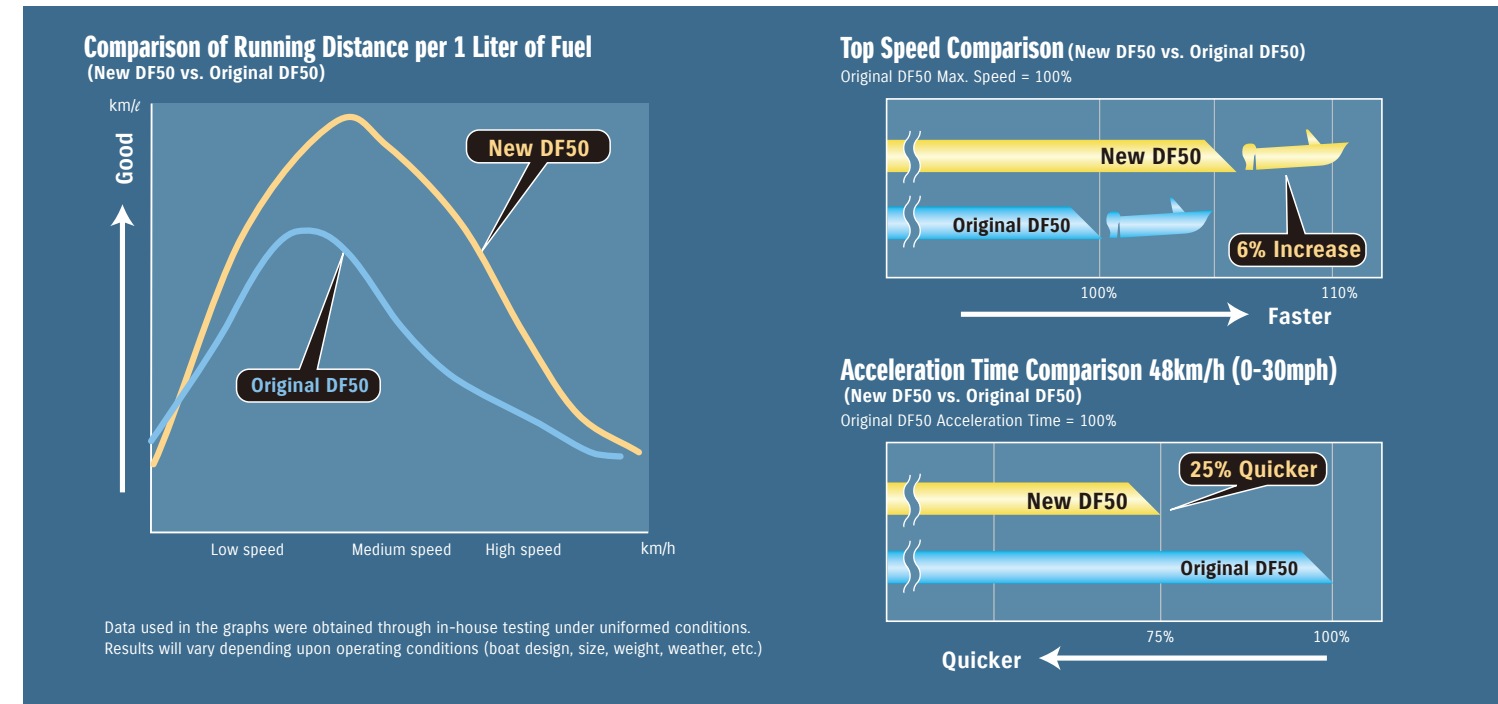

## Maintenance Free Timing Chain

The DF50 and DF40 are the only outboards in the 36.8kW (50PS)/29.4kW (40PS) outboard class to incorporate a timing chain. The chain is oil-bathed, self adjusting, and maintenance free to provide boaters with years of dependable service.



## Large capacity 19A Alternator

The DF50 and DF40 are equipped with a powerful 19A alternator that generates approximately 11.5A even with the engine running at a low 1,000 rpm. Under normal circumstances that's enough power to keep an assortment of marine electronics operating in most situations.

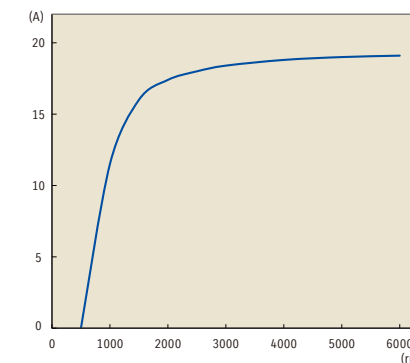

## Multi-Point Sequential Electronic Fuel Injection

Suzuki pioneered the use of multi-point sequential electronic fuel injection in four-stroke outboards. This advanced, time-tested system gathers operating data from a series of sensors located in key areas on the engine, processes the data and calculates the optimum amount of fuel and air needed for the engine—all in real time. Boaters benefit with smooth starts, maximum operating efficiency, excellent fuel economy, and reduced emissions.

## Suzuki's Anti Corrosion System

Suzuki protects the outboard's exterior from harmful corrosion with its own specially formulated anti-corrosion finish. Applying the finish directly to the outboard's aluminum surface, allows maximum bonding of the finish to the surface to increase durability and help protect parts that are constantly exposed to saltwater.

